

PIECES OF OAK WOOD
(Oeno 3/2005, Oeno 430/2010, Oeno 406/2011)

1. OBJECT, ORIGIN AND FIELD OF APPLICATION

Pieces of oak wood used for winemaking and for passing on certain constituents to the wine in conditions set by regulations.

The pieces of oak wood must come exclusively from the *Quercus* genus.

They can possibly be left in their natural state or they can be heated to a low, medium or high temperature but they must not be charred including on the surface, nor be carbonaceous, nor friable when touched.

No compound should be added to them for the purpose of increasing their natural aromatising capacity or their extractible phenolic compounds.

Likewise, they must not undergo any chemical, enzymatic or physical treatment other than heating.

2. LABELLING

The label must mention the varietal origin of the oak and the intensity of any heating, the storage conditions and safety precautions.

3. DIMENSIONS

The dimensions of these particles must be such that at least 95% in weight be retained by the screen of 2 mm mesh (9 mesh).

4. PURITY

The pieces of oak wood must not release any substances in concentrations which may be harmful to health,

5. STORAGE CONDITIONS

The pieces of oak wood must be stored in sufficiently dry and odourless conditions free from substances liable to contaminate them.

6. INTRODUCTION IN WINE

Where bags or other containers are used as the means of introducing pieces of oak wood or related support system into wine, they must be made from materials that are approved for food contact in the country of use, and which do not release any substances into the wine in concentrations which may be harmful to health, or jeopardise to the quality of the final product.

ANNEXE A

Determination of the size of pieces of oak wood by screening
(Oeno 406-2011)**1. Introduction**

The use of pieces of oak wood, commonly called chips, to treat wine is authorised provided they comply with the specifications of the Oenological Codex (resolution OENO 3/2005). In particular, the pieces of oak wood used must meet a size requirement, and it is specified that "The dimensions of these particles must be such that at least 95% in weight be retained by the screen of 2 mm mesh (9 mesh)". The following operating procedure provides a method of sampling and then screening that can be used to verify this requirement.

2. Field of application

The method applies to oak wood test samples of more than 0.5 kg.

3. Principle

After dividing up the initial test sample, a known quantity of pieces of oak wood (approximately 200g) is placed on a vibrating screen. By weighing the pieces of oak wood remaining on the screen after shaking, it is possible to determine the percentage by weight of particles retained by the screen.

4. Equipment

- Standard laboratory equipment.
- Screen of 2 mm mesh (9 mesh), 30 cm in diameter, mounted on a vibrating plate provided with a recovery tray.
- Weighing machine capable of weighing to within 0.1 g.
 - Slotted test specimen divider (see figure below as an example).

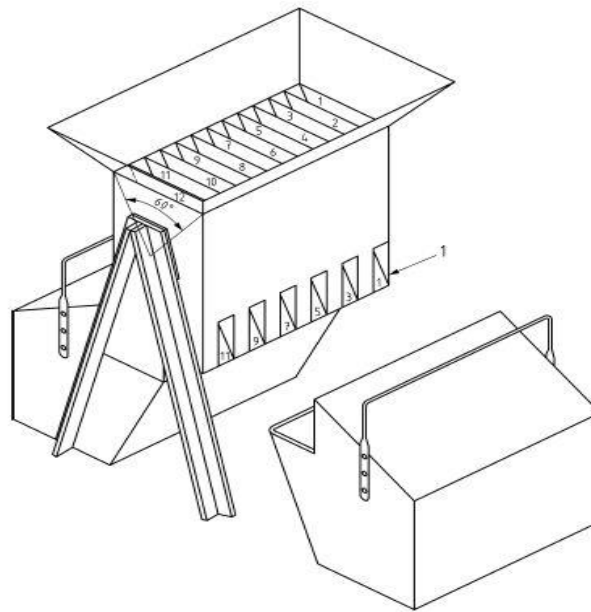

1 Alternating sections on
either side

échantillons à fentes

Slotted test sample divider (EN 1482-1: 2007)
Scheme proposed as an example

5. Division of test sample

When the size of the test sample has to be reduced to obtain "sub-samples" of 200 g which retain a homogeneous nature representative of the initial test sample, a slotted test sample divider can be used which allows random separation of the test sample into 2 parts.

The test sample is poured entirely into the divider in order to separate it into two statistically equivalent parts. Half is put aside, while the other half is again split by means of the chip spreader. This operation is repeated as often as necessary, half being eliminated at each stage with the aim of obtaining 2 "sub-samples" of about 200 g each.

6. Operating procedure

- Weigh the empty screen (W_{ES}).
- Weigh the empty recovery tray (W_{ET}).
- Tare the screen + recovery tray unit and place on it about 200 g of pieces of oak wood weighed to within 0.1 g. Let W_{OAK} be the weight of the pieces of oak wood to be screened.
- Place the unit on the vibrating plate and close the cover with the clamping loops.
- Start up the device and allow it to vibrate for 15 minutes.
- Weigh the screen containing the remaining particles that have not passed through the 2mm meshes (W_{PS}).
- Weigh the recovery tray containing the particles that have passed through the screen (W_{PT}).

A second test is performed in these conditions on the second sub-sample of pieces of oak wood coming from the same initial test sample.

Comment: Weighing of the recovery tray before and after screening (W_{RT} and W_{PT}) serves to verify that there has been no loss of test sample during the operation.

One should have: $W_{ES} + W_{ET} + W_{OAK} = W_{PS} + W_{PT}$

7. Calculation

The percentage (by weight) of particles retained by the screen of 2mm mesh is given by the following formula:

$$\% \text{ of particles retained} = \frac{(W_{PS} - W_{ES}) \times 100}{W_{OAK}}$$

This calculation is performed for each of the 2 sub-samples coming from the initial test sample; the percentage of particles retained corresponds to the mean of the 2 results.

8. Bibliography

Resolution OENO 3/2005 PIECES OF OAK WOOD
EN1482-1 - Fertilizers and liming materials. Sampling and sample preparation. Part 1: Sampling.